



# EMGA

1320 - 2,5 mm

1520 - 2 mm

**ANGRAJLI  
GİYOTİN MAKAS**  
MOTORIZED  
GUILLOTINE SHEAR



**Döküm Taşlanmış Tabla**  
Cast Iron Ground Table



**Arka Dayama 600 mm**  
Back Gauge 600 mm



**Tabaka Saclar İçin Ön Destek Kolları**  
Front Support Arms



## GENEL ÖZELLİKLER

- Pik döküm ayaklar , Platina tabla ve üst çene
- Kesme anında sacın kaymasını önleyen mekanik baskı sistemi
- Üst çene için ayarlanabilir kızaklar , Dar ve ince sacların kesimine uygun arka dayama sistemi
- Dört ağızlı kullanılabilen tek parçalı 2379 çelik bıçaklar
- Kolay ayarlanabilen sentil ayar sistemi , Bıçakların üst üste binmesini önleyen bindirmezlik sistemi , Tek ve seri kesmeye elverişli ayak pedal sistemi
- Dik kesim sağlayan milimetrik gönye , Sessiz çalışan kavrama sistemi , Geniş ve açılı sac kesmeye uygun ön gönye ve ön kollar.
- Ana mil ve eksantrik kollar için okuyucu sac muhafaza , Volan için koruyucu muhafaza

## GENERAL FEATURES

- Cast iron frames and base Steel Plate and Upper Jaw
- Mechanical Sheet fixer to avoid slipping , Adjustable sledges for Upper jaw, Adjustable back gauge for narrow and short parts
- 4 sided 2370 quality high tensile steel blades
- Easy setting of blade gap , Preventor mechanism for blades overlapping, Foot pedal system to arrange for single or multi-cuts
- Sensitive Frame to enable Clear perpendicular cuts , silent clutch system, Adjustable front gauges to enable wide piece cutting
- Sheet cover For main shaft and eccentric arms , Cover sheet for flywheel

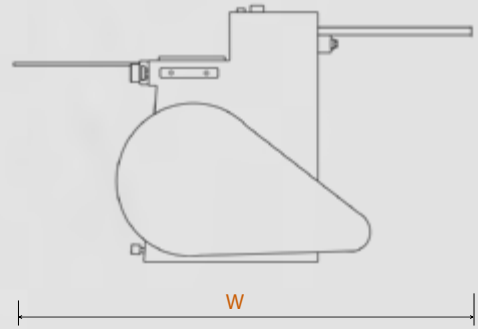
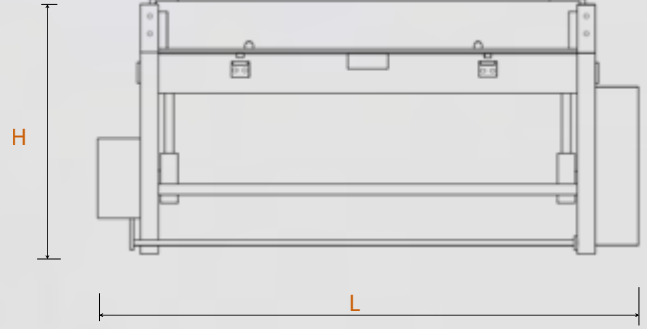

			1320x2,5	1520x2,0
	<b>EMGA</b>			
Tabla Ölçüsü	Table Dimension	mm	380x1420	380x1620
Bıçak Boyu	Blade Length	mm	1310	1510
Kesme Boyu	Shearing Length	mm	1300	1500
Kesme Kapasitesi (Siyah Sac)	Shearing Capacity (Mild Steel)	mm	2,5	2,0
Kesme Kapasitesi (Paslanmaz)	Shearing Capacity (Stainless)	mm	1,2	1,0
Dakika / Kesim	Cut / Per Minute	X	80	80
Motor Gücü	Motor Power	kW	3	3
Arka Dayama Açıklığı	Back Gauge Length	mm	600	600
<b>L</b> Uzunluk	<b>L</b> Length	mm	1550	1850
<b>W</b> Genişlik	<b>W</b> Width	mm	840	840
<b>H</b> Yükseklik	<b>H</b> Height	mm	1200	1200
Ağırlık	Weight	kg	900	1200

