

DK

1900/200 200 Ton

1570-150 150 Ton

1570-100 100 Ton

Manometre
Manometer



GEZER PİSTON
MOTORLU (AĞIR TİP)
MOBILE PISTON
MOTORIZED (HEAVY DUTY)



Yağ Tankı
Oil Tank



**Kremiyerli Gezer
Kafa Piston**
Geared Moveable
Piston by
Hand Wheel

**Ayarlanabilir Alt
Tabla**
Adjustable Bottom
Table

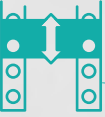

**Kumanda Kolu ile
Kontrol**
Joystick Control



GENEL ÖZELLİKLER

- Kolay kullanım imkanı
- Çelik konstrüksiyon kaynaklı gövde
- İstenilen noktada durdurma imkanı
- Basınç göstergesi (manometre)
- Aşırı yüklemelere karşı emniyet ventili
- Kumanda kolu ile kontrol
- Ayarlanabilir alt tablalar
- Tabla indirme-kaldırma tertibatı
- Takım olarak işlenmiş V-yatakları
- **Kremiyerli gezer piston**
- **Özel çift hız kumanda kolu ile kontrol**
(DK 1570x100 ve DK 1570x150)

GENERAL FEATURES

- Easy to operate
- Steel construction welded frame
- Ability to stop any position
- Manometer
- Relief valve for overloading
- Joystick control
- Adjustable bottom tables
- Table up-down movement attachment
- A pair of V-blocks
- **Geared moveable piston by hand wheel**
- **Dual speed joystick control**
(DK 1570x100 and DK 1570x150)

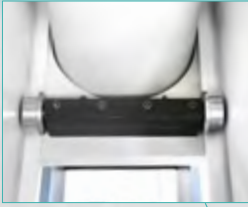

DK
1570-150



V-Yatağı
V-Blocks



OPSİYONEL

OPTIONAL



El Pompası
(200 TON Hariç)
Hand Pump
(Except 200TON)



Ayak Pedalı
Foot Pedal



Dijital Kurs Göstergesi
Digital Stroke Read out



Limit Switch
Limit Switch

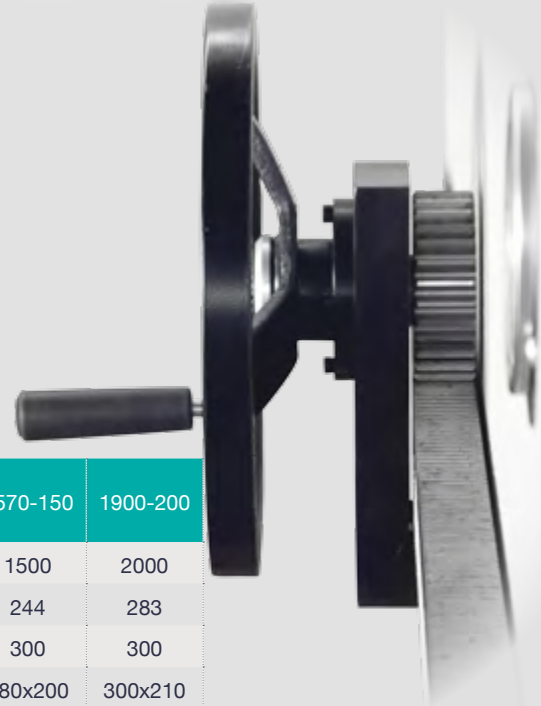
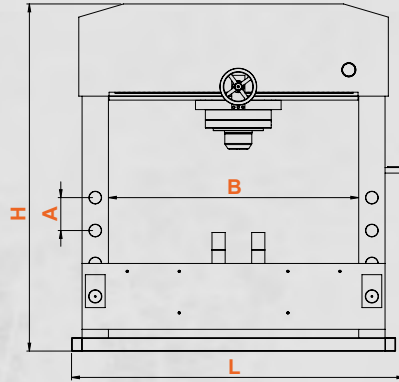
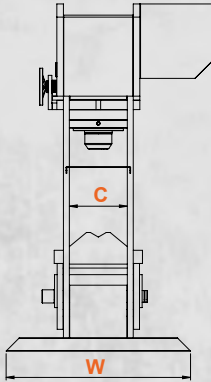

DK

			1570-100	1570-150	1900-200
Basma Gücü	Press Power	kN	1000	1500	2000
Maks. Çalışma Basıncı	Max. Working Pressure	bar	263	244	283
Kurs	Stroke	mm	300	300	300
Piston Kol Çapı	Diameter of Piston Arm	Ømm	220x160	280x200	300x210
İniş Hızı	Advance Speed	mm/sec	8	9	10
İş Hızı	Working Speed	mm/sec	5	5	5
Geri Dönüş Hızı	Return Speed	mm/sec	10	10	20
Motor Gücü	Motor Power	kW	5,5	11	15
A Delik Mesafesi	A Hole Distance	mm	190	190	250
B Çalışma Aralığı	B Working Area	mm	1570	1570	1900
C Derinlik	C Depth	mm	315	360	440
L Uzunluk	L Length	mm	2630	2630	2570
W Genişlik	W Width	mm	1000	1000	1665
H Yükseklik	H Height	mm	2625	2625	2860
Ağırlık	Weight	kg	1755	2350	4800