

DP

600-30 30 Ton

500-20 20 Ton

500-10 10 Ton

MANUEL KOLLU
MANUAL ARM



Manometre
Manometer

V-Yatağı
V-Blocks



Ayarlanabilir Piston Başı
Adjustable Piston Crown

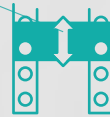

Ayarlanabilir Alt Tabla
Adjustable Bottom Table

GENEL ÖZELLİKLER

- Kolay kullanım imkanı
- Çelik konstrüksiyon kaynaklı gövde
- İstenilen noktada durdurma imkanı
- Basınç göstergesi (manometre)
- Ayarlanabilir alt tablalar
- Takım olarak işlenmiş V-yatakları

GENERAL FEATURES

- Easy to operate
- Steel construction welded frame
- Ability to stop any position
- Manometer
- Adjustable bottom tables
- A pair of V-blocks



DP
500-20

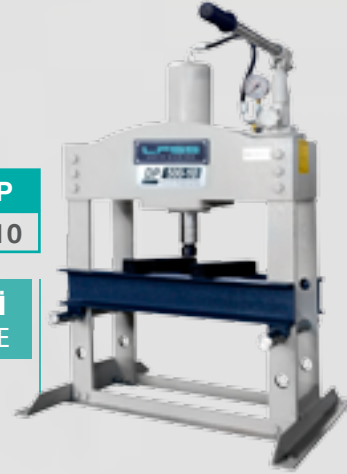

DP
500-10

MASA TİPİ
TABLE TYPE

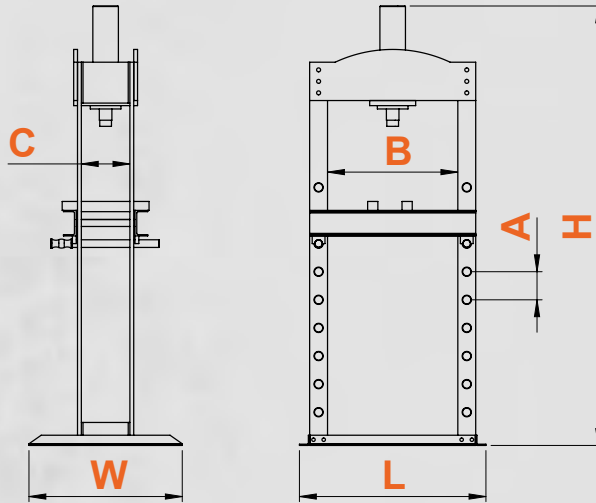

DP

			500-10	500-20	600-30
Basma Gücü	Press Power	kN	100	200	300
Maks. Çalışma Basıncı	Max. Working Pressure	bar	244	244	244
Kurs	Stroke	mm	125	125	125
Piston Kol Çapı	Diameter of Piston Arm	Ømm	80	85	90
A Delik Mesafesi	A Hole Distance	mm	200	200	200
B Çalışma Aralığı	B Working Area	mm	400	400	550
C Derinlik	C Depth	mm	190	190	190
L Uzunluk	L Length	mm	610	610	750
W Genişlik	W Width	mm	500	750	650
H Yükseklik	H Height	mm	1325	1570	1790
Ağırlık	Weight	kg	100	110	160