

DPM-K

1070/1570-150 150 Ton

1040-80 80 Ton

1070/1570-100 100 Ton

1040-60 60 Ton

775 - 30 30 Ton

GEZER PİSTON
MOTORLU
MOBILE PISTON
MOTORIZED

Rulman Hareketli Gezer Piston
Ball Bearing Mobile Piston



Manometre
Manometer

Piston Hareket Kilit Mekanizması
Piston Movement Lock System



V-Yatağı
V-Blocks



Özel Çift Hız Kumanda Kolu
Dual Speed Joystick



Ayarlanabilir Alt Tabla
Adjustable Bottom Table

GENEL ÖZELLİKLER

- Kolay kullanım imkanı
- Çelik konstrüksiyon kaynaklı gövde
- İstenilen noktada durdurma imkanı
- Basınç göstergesi (manometre)
- Aşırı yüklemelere karşı emniyet ventili
- Özel çift hız kumanda kolu ile kontrol
- Ayarlanabilir alt tablalar
- Tabla indirme-kaldırma tertibatı
- Takım olarak işlenmiş V-yatakları
- Rulman hareketli gezer piston

GENERAL FEATURES

- Easy to operate
- Steel construction welded frame
- Ability to stop any position
- Manometer
- Relief valve for overloading
- Dual speed joystick control
- Adjustable bottom tables
- Table up-down movement attachment
- A pair of V-blocks
- Ball bearing mobile piston



DPM-K
1040-60

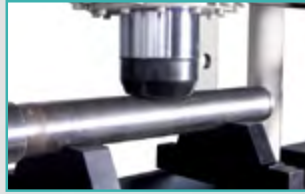

OPSIYONEL

OPTIONAL



El Pompası
Hand Pump



Ayak Pedalı
Foot Pedal



Dijital Kurs Göstergesi
Digital Stroke Read out



Limit Switch
Limit Switch

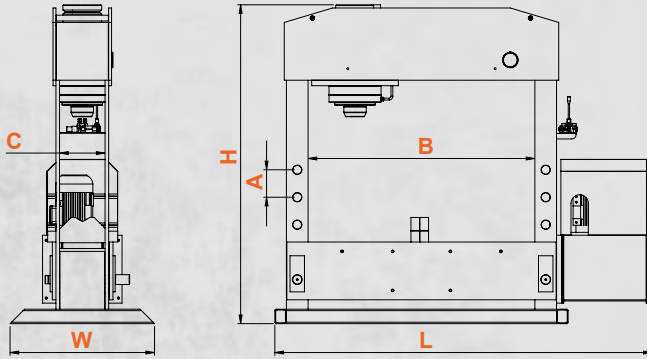

DPM-K
1040-80

 DPM-K			775-30	1040-60	1040-80	1070-100	1570-100	1070-150	1570-150
Basma Gücü	Press Power	kN	300	600	800	1000	1000	1500	1500
Maks. Çalışma Basıncı	Max. Working Pressure	bar	244	236	255	263	263	244	244
Kurs	Stroke	mm	200	250	250	300	300	300	300
Piston Kol Çapı	Diameter of Piston Arm	Ømm	125x80	180x120	200x120	220x160	220x160	280x200	280x200
İniş Hızı	Advance Speed	mm/sec	7,5	8	8	8	8	9	9
İş Hızı	Working Speed	mm/sec	5	4	5	5	5	5	5
Geri Dönüş Hızı	Return Speed	mm/sec	10	10	10	10	10	10	10
Motor Gücü	Motor Power	kW	3	4	5,5	5,5	5,5	11	11
A Delik Mesafesi	A Hole Distance	mm	165	165	165	190	190	190	190
B Çalışma Aralığı	B Working Area	mm	775	1040	1040	1070	1570	1070	1570
C Derinlik	C Depth	mm	190	260	260	315	315	360	360
L Uzunluk	L Length	mm	1500	1710	1810	2110	2630	2110	2630
W Genişlik	W Width	mm	700	700	750	1000	1000	1000	1000
H Yükseklik	H Height	mm	1800	2100	2100	2430	2430	2480	2480
Ağırlık	Weight	kg	400	800	835	1500	1600	1870	2100