



## HPK 40

**HİDROLİK  
PROFİL & BORU  
KIVIRMA**  
HYDRAULIC  
PROFILE & PIPE  
BENDING



**3 Top Tahrıklı**  
Three Rolls Powered



**Dijital Gösterge**  
Digital Read-out



**Yatay Çalışma Pozisyonu**  
Horizontal Working Position

### GENEL ÖZELLİKLER

- Küresel grafitli dökme demir gövde
- 3 top tahrıklı
- Vals topları sertleştirilmiştir
- Vals milleri özel çelikten, sertleştirilmiş ve taşlanmıştır
- Standart vals topları
- Ayarlanabilir yan dayamalar
- Dijital gösterge
- Yatay ve dikey çalışma imkanı

### GENERAL FEATURES

- Stable cast steel frame
- Three rolls are powered
- Hardened rolls
- Rolls shafts are special hardened steel and ground
- Standard rolls
- Adjustable guide rolls
- Digital readout
- Horizontal and vertical working position

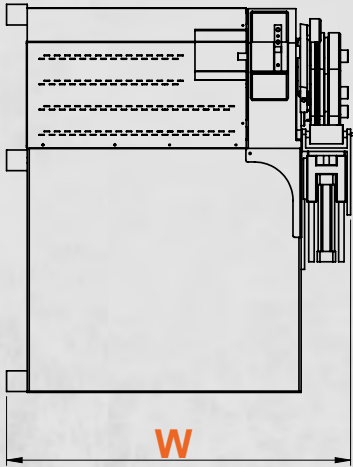
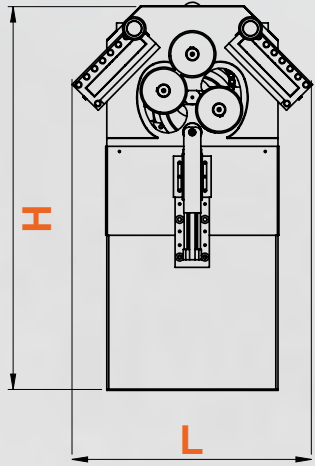

OPSİYONEL

OPTIONAL



**Boru Bükme Vals Topları**  
Pipe / Tube Bending Rolls



**Özel profil bükme valsleri**  
Profile bending rolls



**Spiral bükme vinci**  
Spiral bending crane



**NC Kumanda Paneli**  
NC Control Unit



HPK

40

Mil Çapları	Roll Shafts	Ømm	40
Üst Vals Topu Çapı	Upper Roll Diameter	Ømm	137
Çalışma Hızı	Working Speed	m/min	7
Motor Gücü	Motor Power	kW	1,1
L Uzunluk	L Length	mm	1050
W Genişlik	W Width	mm	530
H Yükseklik	H Height	mm	1250
Ağırlık	Weight	kg	350

